



TESTING MACHINES, INC.

The Finest Test Equipment for all Industries

49-85/86/87 MICROMETERS



PLEASE READ BEFORE OPERATING UNIT



Molenbaan 19
2908 LL Capelle aan den IJssel
The Netherlands

☎ +31(0) 10 - 79 00 100
✉ info-ic@industrialphysics.com
🌐 www.tqcsheen.com

Part of the Inks & Coatings division of Industrial Physics:
   
www.industrialphysics.com/ic



TESTING MACHINES, INC.

The Finest Test Equipment for all Industries

*Worldwide Headquarters
Sales and Service*

40 McCullough Drive
New Castle, DE 19720 USA
Phone: 302-613-5600
Toll Free: 800-678-3221
Fax: 302-613-5619
www.testingmachines.com

Dear Valued Customer:

You are now the proud new owner of quality physical testing equipment manufactured by Testing Machines Inc., the industry's leader for over 80 years. TMI has a long-standing commitment to quality products and customer satisfaction.

To aid in setup, calibration, and operation of all Testing Machines Inc. equipment, we offer telephone assistance by our Technical Support Department, available Monday through Friday from 8:30 AM to 5:00 PM EST. TMI also offers on-site Preventative Maintenance and Calibration service.

Please take the time to fill out the postage paid Warranty Card completely and return it to us. Your comments make it possible for us to evaluate how well we are servicing your needs.

In the unlikely event that your equipment requires warranty repair service, or if you need to arrange for non-warranty repair service, please follow the instructions on the repair policy page located in this manual. Supplying the requested information on the repair policy page enables our Technical Support Staff to service your needs faster.

Please contact us at (302) 613-5600 if additional information is required.

Sincerely,

Testing Machines, Inc.

IMPORTANT SAFETY INSTRUCTIONS

Read all of these instructions carefully before operating the instrument.

1. Save these instructions for future reference.
2. Follow all warnings and instructions that are marked on the instrument.
3. Unplug the instrument from the wall outlet before cleaning. Wipe the outside surfaces with a damp cloth only.
4. Do not use this instrument near water.
5. Do not place the instrument on an unstable cart, stand, or table.
6. Only operate the instrument from the type of power source indicated on the label.
7. For safety, this product is equipped with a three-wire grounding type plug. This plug will only fit into a grounding type power outlet. If you are unable to insert the plug into the outlet, contact your electrician to replace the outlet with the proper type. **Do not defeat the purpose of the grounding-type plug.**
8. Do not allow anything to rest on the power cord. Do not locate this product where persons will walk on the cord.
9. If an extension cord is used with this product, make sure that the total ampere ratings of the product(s) plugged into the extension cord do not exceed the extension cord ampere rating. Extension cords must have a minimum insulation rating of 600v.
10. Do not remove any panels from the tester. Never push objects of any kind into any openings in the instrument's covers. Failure to heed this warning could result in fire or electric shock. Never spill liquid of any kind on the instrument.
11. Do not attempt to service this product yourself. Opening or removing covers may expose you to dangerous high voltages.



12. At the end of its service life, dispose of the product according to the relevant statutory regulations.
13. Refer all servicing to Testing Machines' Technical Support Staff:

Testing Machines Inc.
Customer Service Department
40 McCullough Drive
New Castle, DE 19720 USA
Phone: (800) 678-3221 or (302) 613-5600
Fax: (302) 613-5619
Email: responsecenter@testingmachines.com
Web: www.testingmachines.com

14. Unplug the unit from the wall outlet and refer servicing to qualified service personnel under the following conditions:
 - ◆ When the power cord or plug is damaged or frayed.
 - ◆ If liquid has been spilled into the product.
 - ◆ If the product has been exposed to rain or water.
15. Adjust only those controls that are covered by the operating instructions. Improper adjustments of other controls may result in damage to the instrument and will often require extensive work by a technician to restore the unit to normal operation.

16. Back-up Battery:

Inside the Instrument tester a CR2032 type coin battery is used on the microcontroller PCB to provide the necessary power to the timekeeping memory chip of the instrument during the power off period. This to maintain the clock, calendar and setup information.



When the battery is worn out it may only be replaced by a trained service engineer!
When the battery is worn out dispose it under the ordinance of each local government or the law issued by relating government.



The battery contains organic electrolyte.
In case of electrolyte leakage from the battery, and an eventual contact with this electrolyte to the operator the actions described below are required.

In case of eye contact:

Flush the eyes with plenty of clean water for at least 15 minutes immediately, without rubbing. Take a medical treatment. If appropriate procedures are not taken, this may cause an eye irritation.

In case of skin contact:

Wash the contact areas off immediately with plenty of water and soap. If appropriate procedures are not taken, this may cause sores on the skin.

In case of inhalation:

Remove to fresh air immediately. Take a medical treatment

In case of electrolyte leakage, take it up with absorbent cloth.
This may only be done by a trained service engineer!

17. Instrument Labels:

The following labels can be found on the instrument.



Earth (Ground)



Electrical Shock Warning



Consult the Operator's Manual

Table of Contents

INTRODUCTION	6
APPLICATION	6
SPECIFICATIONS	6
LIST OF EQUIPMENT	7
CALIBRATION GAUGE.....	7
FEATURES.....	7
NAME AND FUNCTION OF PARTS	8
SETUP	12
OPERATION.....	12
INTRODUCTION	16
PARALLELISM CHECK/ADJUSTMENT.....	16
STATISTICS	15
SERIAL DATA OUTPUT	15
MAINTENANCE	18

**OPERATING INSTRUCTIONS
FOR
DIGITAL MICROMETERS
49-85,86,87 SERIES**

INTRODUCTION

The TMI Digital Micrometer 49-8X Series measures the thickness of sheet material in the following ranges:

Depending on the Model

49-85 and 49-86

0-0.050 in (Imperial Units)

0-1.27 mm (SI Units)

49-87

0-0.500 in (Imperial Units)

0-12.7 mm (SI Units)

The TMI Digital Micrometers – 49-8X Series combines a precision thickness measuring system with a digital readout. The motor-driven instrument utilizes the dead weight micrometer principle. Each unit has been designed and manufactured for use where the utmost precision is required, completely free of operator influence.

The instrument consists of a heavy, solid frame which supports the unit and houses the thickness measurement transducer and associated circuitry. A digital readout is provided to automatically display the actual specimen thickness. The lower anvil as well as a movable pressure foot is made from lapped, stainless steel.

APPLICATION

The TMI Micrometer is designed to measure the thickness or caliper of paper sheets, films and foils. Almost any material including paper, natural or synthetic fabrics, leathers, metals, plastics and rubber thickness can be measured with precision and accuracy. The 49-86 and 49-87 models also feature an on board statistics package that stores up to 100 readings, calculates and displays the average, standard deviation, maximum and minimum of the readings that are stored in the instrument's temporary memory.

SPECIFICATIONS

Dimensions: 7 in. (15cm) wide x 12 in. (30.5cm) high x 9.5 in. (24cm) deep

Approximate Weight: 22 lb. (10kg)

Power Requirements: 90-264VAC, 50/60 Hz

Ranges of Measurement: **For Models 49-85 and 49-86:**
Imperial Units; 0-0.050 in. x 0.0000254 in. resolution
SI Units; 0-1.270mm x 0.0005mm resolution

For Models 49-87:
Imperial Units; 0-0.50 in. x 0.0000254 in. resolution
SI Units; 0-12.70mm x 0.0005mm resolution

Available Accessories:

For Models 49-85 and 49-86:

TMI # 35-12-02 Gauge Blocks for accurate calibration
(.010 in./254mm, .020 in./508mm, .030 in./762mm, .040 in./1.016mm
and .050 in./1.270mm in thickness)

For Models 49-87:

TMI # 35-12-03 Gauge Blocks for accurate calibration
(0.010 in./254mm, .100 in./2.54mm, .200 in./5.08mm,
.300 in./7.62mm, .400 in./10.16mm and .500 in./12.70mm in thickness)

STANDARDS

TAPPI T 411, ISO 534, DIN 53105, ISO 3034, APPITA 1301.426, PAPTAC D.4, ISO 12625-3,
ISO 037, ASTM F2251, ISO 5084



NOTE: Only the 49-8X configured with the appropriate pressure foot and dead weight is capable of meeting above standards

LIST OF EQUIPMENT

- 1 TMI Digital Micrometer
- 1 Instruction Manual
- 1 Box with Packing Material



NOTE: Carefully check all small wrappings, boxes, and envelopes to be sure all parts and supplies are accounted for.

CALIBRATION GAUGE

To check the calibration properly, the user of the micrometer should have the necessary gauge blocks on hand. **The gauge blocks can be ordered separately from TMI.** See Section 3 – Specifications.

SAVE THE BOX

Remove the micrometer from the case with the greatest of care. Do not use the pressure foot, the anvil or the spindle as a handle. Grasp the instrument by the base only.

Please save all the original packing material from the micrometer. In the event the tester needs to be returned, it must be packaged in the original shipping carton after receiving approval and a Return Authorization Number (RA#) from TMI's Customer Service Department.

FEATURES

- Digital readout and superior mechanical design
- Serial output for simple data collection
- Compact, for use throughout the laboratory and production floor
- Special anvil diameters and dead weight loads available on request

NAME AND FUNCTION OF PARTS

All the part names and their descriptions that are listed below can be found in Figure 1 and Figure 2... for Model #'s 49-85, 49-86, and 49-87.

1. **Display Window:** The digital display window shows the thickness of the specimen measured.
2. **Cycle Button:** This Button is located on the front right side, a blue illuminated push button switch. This button stops the anvil spindle and pressure foot from moving.
3. **Zero Button:** Pressing this will tell the machine to zero itself the next time that it comes to rest on the lower platen or other static object. (In Menu this button will move the highlighted area between different options.)
4. **Units Button:** This button is located on the middle of the front panel. In the 49-85 instrument, this button will cycle the units through μm , mils, millimeters, and inches. (In Menu this button will cycle through available options for the highlighted setting or accept the selected command depending on the menu.) In the 49-86 and 49-87 instruments, the UNITS button is used to access and navigate through the statistics pages as well as the Menu page.
5. **Split Weight:** TMI # 49-76-00-15 (Standard Model, 2 pieces of the afore mentioned part number make this weight)
6. **Lower Anvil:** A testing surface that is optically flat. The specimen is placed on the anvil's surface and when the pressure foot comes down, a reading is obtained.
 - a. TMI # 49-01-07-016 (Standard Unit)
7. **Set Screws:** The three set screws are for the parallelism adjustment. (3) 10-32 x 5/8 set screws.
8. **Pressure Foot:** This part will move up and down once the machine is operating. The pressure foot is the part that comes down on the specimen when the actual measuring is being performed. TMI # 49-60-01-049 (Standard model)
9. **Anvil Spindle:** The spindle anvil will move up and down carrying the weight and pressure foot with it.
10. **On/Off Switch:** The main power is switched on and off on this unit by a switch located on the back on the unit built into the power entry module.
11. **Serial Output:** This unit has been fitted with RS-232 output via a Mini USB connector.
 - a. Serial Communication Parameters
A Null Modem is not required
 - i. Baud: 9600 bps
 - ii. Data Bits: 8
 - iii. Parity: None
 - iv. Stop Bits: 1
 - v. Flow Control: None
12. **AC Line Cord Connection:** The style of the line cord that is supplied with the unit is decided by the country that the unit is being used.

13. Fuse: 0.25 Amps. TMI # 680-075

a. **Fuse Drawer:** TMI # 680-062

b. (The Fuse is located inside the Fuse Drawer. you must depress two tabs, one on either side, on the fuse drawer to remove it.)



Note:

*In case of a blown fuse it needs to be replaced by one that has the identical shape and the same current rating. In this case **always disconnect the power cord** from the AC power inlet of the instrument before opening the fuse holder.*



Do not use fuses with a higher current rating than the original as this can cause damage to the instrument!

The use of repaired fuses, and/or short circuiting the fuse holder is prohibited!

14. Base Plate: The solid plate that the machine stands on.

15. Rubber Foot: To make sure the machine stands flat and secure on the ground; the machine has four rubber spacing feet. TMI # 240-001

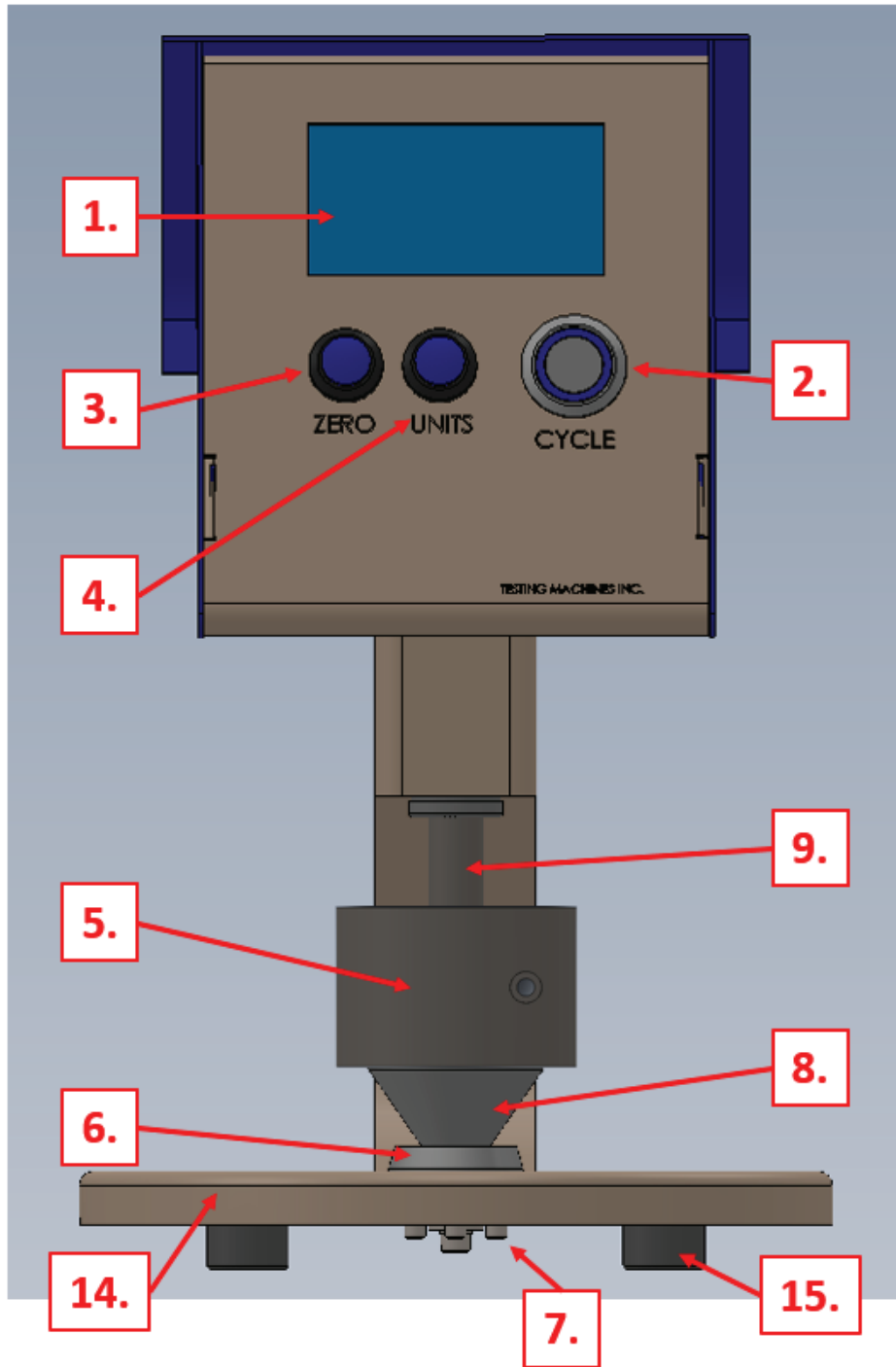

Figure 1.

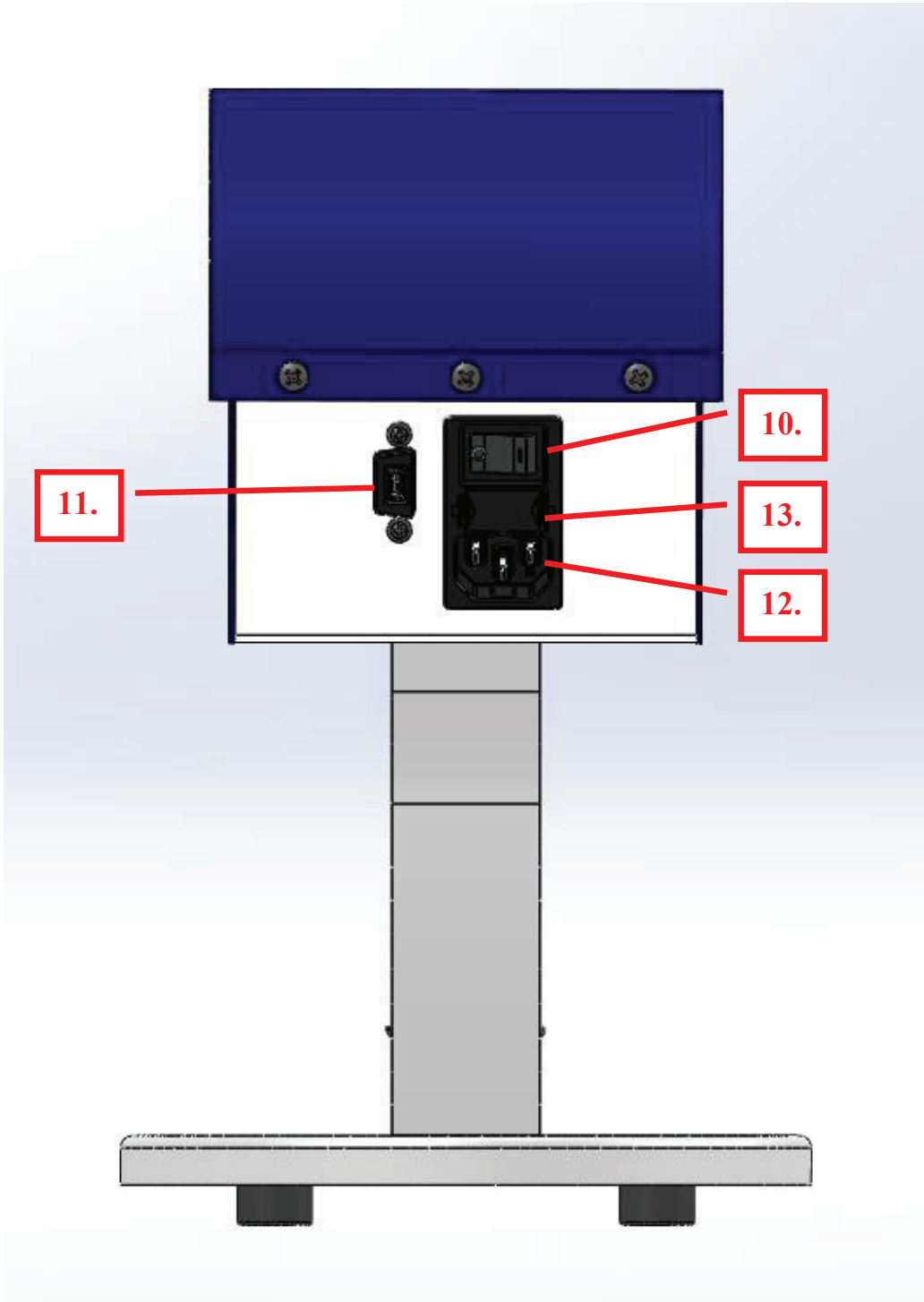

Figure 2.

SETUP

1. Take the micrometer out of the box and place it on a rigid, level bench top, free from large temperature variations, excessive air currents and vibration. Ensure there is appropriate clearance from the rear of the instrument to easily operate the power shutoff device.
2. MAKE SURE TO REMOVE THE SHIPPING COLLAR FROM THE ANVIL SPINDLE.
(The Shipping collar is typically a plastic tube secured by a large cable tie).
3. If included, mount the Split Weight to the micrometer spindle using the included 9/64" Allen Wrench. **(Split Weights are removed for shipping)**



Note:

Please handle the split weights with great care to avoid damage. The edges of the split weights can have sharp edges. Please be aware of the possible danger of cutting yourself!

4. Remove the rubber pad that is located in between the anvils during shipment.
(If the machine has a range of 0.000"-0.050" you will have to gently lift upper anvil enough to slide the pad out).
5. Connect the power cord from the power entry module (located on the back of the unit) to a suitable AC outlet, free from electrical noise and large voltage variations.



Warning:

*If the supplied power plug needs to be adapted to the local power requirements this must be done by a qualified electrical engineer. The plug **must** be equipped with a safety earth terminal.*

Please Note:

Power cord wire colors:

*Brown or Black = Line
Blue or White = Neutral
Yel/Grn or Green = Earth/Ground*



OPERATION

1. **Ensure that the shipping collar has been removed from the unit. Serious damage can occur if the shipping collar has not been removed.**
2. Turn the power switch to the "On" position. At this time, the display and start/stop button will become illuminated. The first screen will only show until the end user confirms that they have removed the restraints. TMI is not liable for damage cause by disregarding this warning.
3. The second screen will now appear. The machine will need to run 2 to 3 cycle to find the limits of its travel. This is done by pressing the Units button. While cycling, the blue LED button should pulse.
4. The third screen will remind you to clean the anvils for optimal performance. Draw a piece of soft-body paper through the pressure foot and anvil; this will remove any foreign matter. Also visually inspect the anvil surfaces for any debris, it might be necessary to use a small amount of rubbing alcohol to clean them.

5. The fourth screen to appear will be the main testing screen. It displays the measured gap, the units, and the time. For best results, allow the micrometer to warm up for approximately 30 minutes minimum before performing any tests. It is highly recommended to always zero the instrument before running samples.
6. **Zero the Micrometer:** To zero the micrometer, press the Zero button on the front panel. Pressing this will tell the machine to zero itself the next time that it comes to rest on the lower platen or other static object.
7. If you wish, you can perform a quick check of your micrometer. This is done with the TMI Gauge Blocks:

For Model 49-85 and 49-86:
TMI # 35-12-02

For Model 49-87:
TMI # 35-12-03

Slip one of the gauge blocks between the pressure foot and the anvil. Ensure that the gauge block is located at the visual center of the anvils. The digital display reading should be the same as the thickness of the gauge block. (See the instrument's calibration record for tolerance.) If the micrometer does not give the correct reading of the gauge block, calibrate the micrometer. (See Section 9 – Calibration of the micrometer.)

8. All samples that are to be tested should be prepared and conditioned according to TAPPI T400 or applicable standards. Each sample should be cut and prepared as described in TAPPI T411 or any other applicable standard. Any samples that are kinked, bent or creased should not be used since this may affect the reading of the sample.
9. Measure the thickness by placing the specimen between the automatically cycling pressure foot and the anvil when they are apart. Ensure that the specimen fully covers the area of contact between the pressure foot and the anvil. During the time when the pressure foot rests on the specimen, the specimen's thickness is measured and displayed on the digital readout. At the end of the cycle time, the pressure foot again moves upward and a new measurement can be made. Be sure to only take one reading at one point on the specimen.

Special Notes on Operation:

- Readings that appear to be slightly out of tolerance have a high likelihood of being caused by trace amounts of debris left on the surfaces of the anvils.

USER OPTIONS MENU (49-86 and 49-87 only)

You may enter the User Options Menu from the main screen by pressing and holding the Units Button and pressing the Zero Button. This menu contains the following options:

Password Protection (optional)

The instrument's Options Menu can be protected by a "manager" password if the user chooses to do so. The default setting for the instrument is 0-0-0-0, which disables the password prompt. To enable a password, select the option and input a 4-digit code **other than** 0-0-0-0.

Note: If you would like to reset the password, use the calibration password. This will reset the password to the factory default (disabled).

Lowering Speed (in mm/s)

Your standard may specify a specific lowering speed. The options are 1, 2, and 5mm/s (10 mm/s 49-87 only)

Dwell Time (in seconds)

Your standard may specify a specific time to wait after the spindle motion stops on the sample before it returns a result. The “0 seconds” option will report a result as soon as the machine registers a stop. Dwell Times over 1 second will pause the motor in order to wait for the reading. The options are 0,1,2,3,4,5, and 6 seconds.

Starting Units

This is the units that the machine will default to when powering on. The options are “ μm ” for micrometers, “mils” for mils, “mm” for millimeters, and inches.

Record Stats:

The options for this setting are **ON** or **OFF**. Statistics can still be viewed if set to **OFF**, but no new readings will be recorded.

Stat Threshold:

The options for this setting are OFF, 2 μm , 4 μm , and 6 μm . These are in metric because the machine is internally a metric machine. Statistics will not be recorded if the reading is within the tolerance band (+/-) around zero.

Zero Threshold:

This sets a small range around a reading of 0.00 to be reported as 0.00. For example: if the machine is set to a Zero Threshold of 2 μm then any reading from -2 to 2 μm will return a reading of 0 μm . The options for this setting are OFF, 2 μm , 4 μm , and 6 μm . These are in metric because the machine is internally a metric machine.

Time:

This line contains several options

- 24Hr or A.M./P.M. – changes between 24 and 12 hour time
- Hours – adds one hour
- Minutes – adds one minute
- Seconds – resets the seconds to zero

Live Readings:

This option changes how the main screen displays the current gap. Turning Live Readings ON will show a constant feed of the updated gap. Turning Live Readings OFF will cause the screen to only update when it has a valid reading. These options will not change how the machine communicates its readings with GraphMaster.

LED Pulse:

This will toggle the Cycle Button’s LED functions between constantly on and pulsing when a test is being conducted. This has no effect on the machine’s function.

Return:

This saves the options and returns you to the main screen.

STATISTICS

The 49-86 and 49-87 models have a statistics feature that allows the user to display the average, standard deviation, maximum, and minimum values of the readings stored in the instrument's temporary memory (this memory is erased when the power to the instrument is turned off).

1. To access the main statistics screen from the main (measurement) screen, press the **UNITS** button.
2. The main statistics screen will display the current reading, the average of the stored readings, the standards deviation of the stored readings and the maximum and minimum of the stored readings.
3. Press the **UNITS** button again to list the readings
 - a. Navigate this screen by pressing the **ZERO** key to highlight \uparrow , \downarrow , **DELETE**, or **RETURN**
 - b. Press the **UNITS** key to act on the highlighted option
 - i. Pressing **UNITS** when the \uparrow is highlighted will scroll the active reading selection box up once.
 - ii. Pressing **UNITS** when the \downarrow is highlighted will scroll the active reading selection box down once.
 - iii. Pressing **UNITS** when the **DELETE** is highlighted will delete the active reading in the selection box.
 - iv. Pressing **UNITS** when the **RETURN** is highlighted will return to the main statistics screen.
 - c. Press and hold the **UNITS** key, then press the **ZERO** key to delete all readings. User confirmation is required for this.
4. Press and hold the **UNITS** key, then the **ZERO** key to return to the Main (measurement) screen.

SERIAL DATA OUTPUT

These Testing Machine Inc. Micrometers (Thickness Gauges) output a string through a mini-USB connector on the back panel of the instrument.

The USB host (PC) will need to be looking for serial data on one of its COM ports. The number of the COM port will vary from host to host.

These are the settings needed to capture the serial data -

Baud rate: 9600
Data: 8 bits
Parity: None
Stop Bit(s): 1
Flow Control: None

Here are some serial string examples-

- Initial string - "CC5.1.1.13;"
 - This is an identifier string used by our GraphMaster product. You can ignore it if you are not using GraphMaster. It will only show up after powering on.
- After each cessation of downward motion, like the spindle coming to rest on a sample, the machine will output a serial data string in the following format.

TM V00.01.02 49-87-00-000112345-67 00000000053+000004.370

- "TM V00.01.02 " - A software version number

- "49-87-00-0001" - The machine's complete model number
- "12345-67" - The machine's serial number. Yours will probably look like 8xxxx-01
- "0000000005" - An identifier for this reading. This resets to zero on powering on and rolls over to 0 after its maximum is reached.
- "3" - The unit of the reading. '3' is mils (thousandths of an inch) and '0' is microns (micrometers)
- "+000004.370" - The reading itself in the units just specified. The '+' is there because the machine can show negative values if zeroed while resting on something besides the platen.

CALIBRATION

INTRODUCTION

This machine has been adjusted and calibrated at the factory. The 49-8X series micrometer has a large portion of its calibration done via a PC. For that reason and the highly technical nature of the calibration we recommend that it only be performed by factory trained personnel. When adjustments and calibration are necessary, refer to the following procedures:

1. Use a set of TMI gauge blocks when calibrating or making adjustments. The set consists of five steel gauge blocks of different sizes. (See Section 3 – Specifications.) These gauge blocks are checked against standards that are traceable to the NIST. The part number for the TMI gauge blocks is as follows:
 - For Model 49-85 and 49-86:**
TMI # 35-12-02
 - For Model 49-87:**
TMI # 35-12-03
2. Turn the micrometer on. Allow the micrometer to warm-up for approximately one half hour before attempting to calibrate.
3. The pressure foot and the lower anvils must be clean and free of dirt. The gauge blocks must be cleaned thoroughly with alcohol before use. Do not touch the working surface with fingers before making any measurements.

PARALLELISM CHECK/ADJUSTMENT (pictures on following page)

Adjustment of parallelism should only be made by a trained professional

1. Always check the anvil parallelism first. Insert one half of the width of the .010 in. gauge block between the anvils on the right side of the unit and take a reading.
2. Insert the same one half of the width of the gauge block between the anvils on the left side of the unit. See Figure 1.
3. Repeat the above procedure for the front, back and center of the anvils.

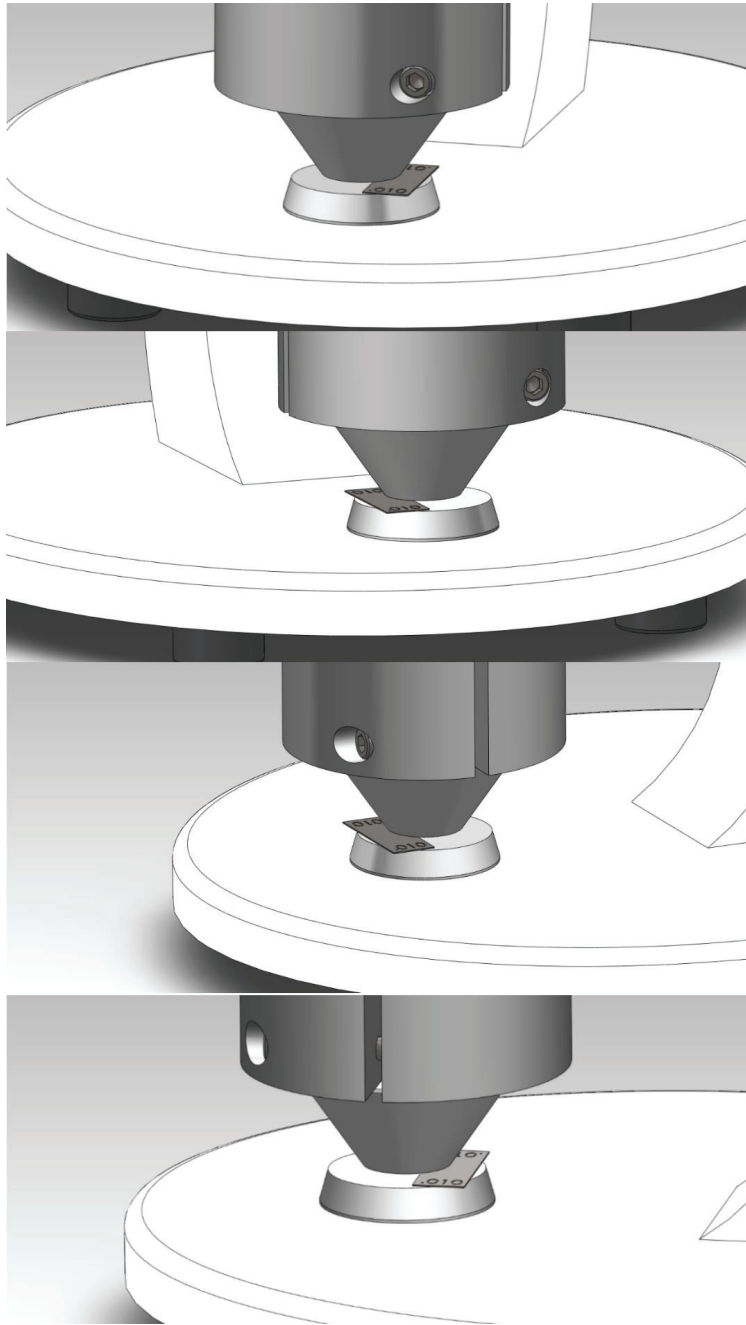

Figure 1

4. **For Model 49-85 and 49-86:***

The readings must be within 0.00004 in. of each other for the anvil and the pressure foot to be considered parallel and no adjustment needs to be done.

For Model 49-87:*

The readings must be within 0.0002 in. of each other for the anvil and the pressure foot to be considered parallel and no adjustment needs to be done.

5. If the parallelism measurements, as described in Section 9.2 – Steps 1 and 2, do not fall within the tolerance range, the anvil needs to be adjusted. Underneath the base plate, there are three leveling screws that attach the anvil to the base plate. Use an Allen key to adjust the leveling screws while securing the nut with a 3/8 in. wrench.

For Model 49-85 and 49-86:*

Adjust the leveling screws until all readings are within .00004 in. (.001 mm) across the anvil's surfaces.

For Model 49-87:*

Adjust the leveling screws until all readings are within .0002 in. (.005 mm) across the anvil's surfaces.

When the adjustments are completed, recheck the parallelism.

* For instruments 49-86-00-0003 and 49-87-00-0003 perform three sets of readings, adjusting the screws each iteration in order to establish a baseline parallelism. Only perform this parallelism adjustment if measurements with gauge blocks placed in the visual center of the anvil are outside the tolerances of the instrument's calibration record.

MAINTENANCE

The TMI Digital Micrometers – 49-8X Series do not require oiling or special maintenance. A rise in operating temperature is expected. The temperature will rise until it reaches operating temperature.

Keep the instrument clean and in an environment that is free of dirt and dust. For consistent test readings, it is very important that the anvil and pressure foot are kept clean.

If the instrument is not in use for an extended period of time, a plastic cover should be used to protect it from dirt and other foreign matter. The pressure foot and the anvil should not be in contact for extended periods of time. Place a piece of paper, film, etc. between the pressure foot and anvil.

TERMS AND CONDITIONS OF SALE

All purchases from TMI are subject to TMI's Standard Terms and Conditions linked below. The TMI Terms and Conditions are an integral part of each business transaction, as indicated in TMI's price bulletins, quotations or order acknowledgements provided.

All materials delivered, services provided, and work performed by TMI are subject to the Terms and Conditions listed on the linked document.

To view and/or download the complete Terms and Conditions of Sale document in PDF format, please visit:

<http://www.testingmachines.com/terms-and-conditions-of-sale>



Molenbaan 19
2908 LL Capelle aan den IJssel
The Netherlands

+31(0) 10 - 79 00 100
info-ic@industrialphysics.com
www.tqcsheen.com

Part of the Inks & Coatings division of Industrial Physics:

